

ENCLOSURE PLAN VIEW 1

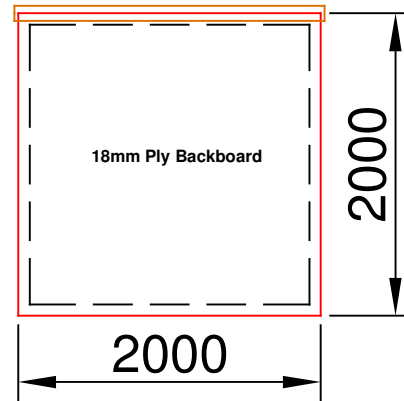

ENCLOSURE REAR VIEW 4

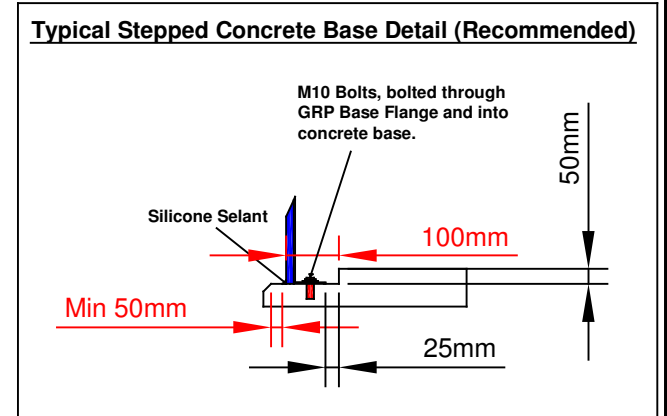

KD-16

OPTIONS LIST

- Any Colour
- 18mm Ply Backboard
- Stainless Steel Hasp & Staple
- Stainless Steel Door Stays (90 Degree)
- Floor: Single Skin
- Floor: Load Bearing
- Cat Flap
- Vents
- Electrics

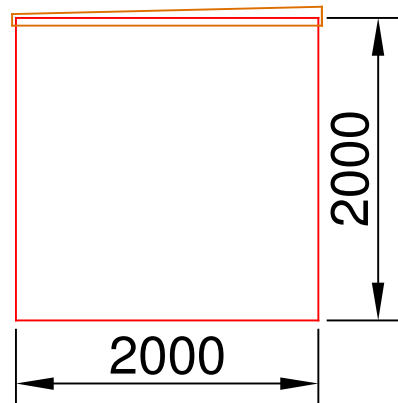

EXTERNAL ELEVATION WALL 2 (SIDE WALL)

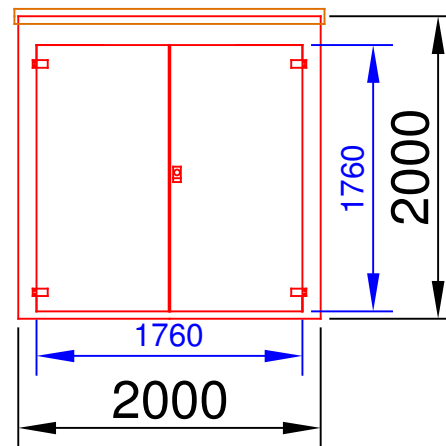

EXTERNAL ELEVATION WALL 1 (FRONT WALL)

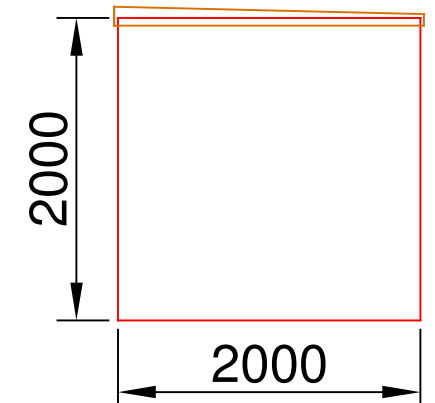

EXTERNAL ELEVATION WALL 3 (SIDE WALL)

Company		Kingsley Plastics Ltd.		External Finish: Semi-Gloss: Smooth		Internal Color: White		External Color: Green (14-C-39)	
Contact				Fire Resistance: BS476 Part 22- 1/2 hr.		Base Flange: 100mm GRP Base Flange		Roof Construction: GRP/12mm Ply/GRP	
Order #				Doors: 1 no. Double Door 1760mm x 1760mm (H)		Ventilation:		Wall Construction: GRP/12mm Ply/GRP	
DWG #	KD-16	Rev		Date	21-10-15	Scale	N/A		