

THIS DRAWING IS A PRIVATE AND CONFIDENTIAL COMMUNICATION AND THE PROPERTY OF KINGSLEY PLASTICS LTD. IT MUST NOT BE COPIED OR LOANED WITHOUT THE WRITTEN CONSENT OF KINGSLEY PLASTICS LTD AND MUST BE RETURNED IMMEDIATELY ON COMPLETION OF TENDER OR CONTRACT.

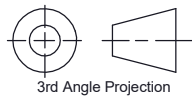

3rd Angle Projection

**Do NOT Scale IF IN DOUBT - ASK !!**

GENERAL MANUFACTURING TOLERANCES: (mm) LINEAR:

0 - 500mm +/- 1.0mm  
500-2000mm +/- 1.50mm  
2000mm + +/- 3.0mm

**REVISIONS**

REV.	DESCRIPTION	DATE	APPROVED
1	First Issue	05-02-18	

**NOTE :-**

- OTHER COLOURS AVAILABLE ON REQUEST.  
- CONTACT OUR SALES DEPARTMENT  
- ALL FINISHES ARE SMOOTH, NOT TEXTURED.



**KINGSLEY PLASTICS LTD**

Western Barn Industrial Park, Hatherleigh Road, Winkleigh, Devon, EX19 8AP

T: 01837 83154 F: 01837 83529 Sales@kingsleyplastics.co.uk www.kingsleyplastics.co.uk

**Standard Finish & Colour Specifications :-**

**CARCASS**

SURFACE FINISH	EXTERIOR COLOUR	INTERIOR COLOUR
Smooth	RAL 6005	RAL 6005

**ROOF**

SURFACE FINISH	EXTERIOR COLOUR	INTERIOR COLOUR
Smooth	RAL 6005	RAL 6005

**DOOR SET**

SURFACE FINISH	EXTERIOR COLOUR	INTERIOR COLOUR
Smooth	RAL 6005	RAL 6005

**Customer Details:**

Customer: -  
Project Name: -  
Customer Ref: -  
Customer Ref Rev: -

**Specification Summary:**

Construction :  
[GRP\\_Four Piece](#)  
Panel Construction / SR Rating :  
[Single Skin](#)  
Overall Door Specification Summary :  
[Single Skin\\_Louvered](#)  
-  
Overall Lock Specification Summary :  
[Quarter Turn\\_Tri Lobe Cabinet Lock](#)  
-  
Overall Vent Specification Summary :  
[63 Dia As shown.](#)  
-  
Roof Type & Construction :  
[Angled](#)

**Additional Notes :**

GRP CONSTRUCTION - FREE AIR FLOW - 3% FLOOR AREA.

**Drawing Title:**

[Gas Cabinet with Plinth No. 7](#)  
[Standard\\_Floor Standing](#)

Drawn By: DJD | First Drawn Date: 05.02.18

**GRP Enclosure Weights & Dimensions:-**

INTERNAL Size (m) :-	<b>W 1610</b>	<b>D 866</b>	<b>H 1661</b>
EXTERNAL Size (m) :-	<b>W 1620</b>	<b>D 875</b>	<b>H 1665</b>

Enclosure Weight :- **68 Kg**

Drawing / Part No:

**Gas Cabinet No. 7**

Current Rev: **2**

**SECTION E-E**

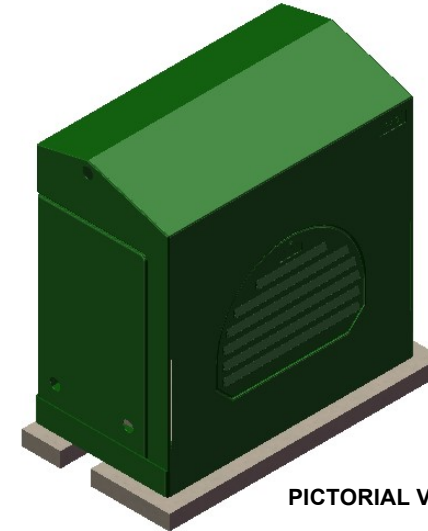
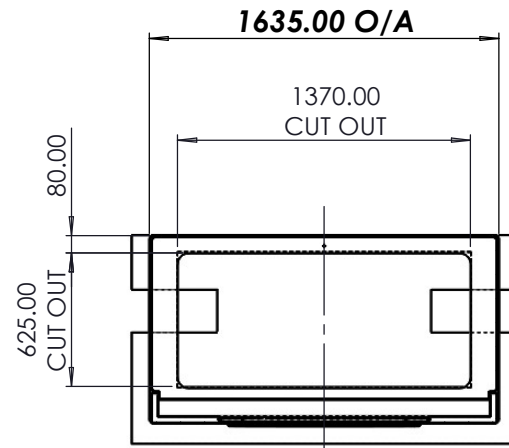

**PICTORIAL VIEW**

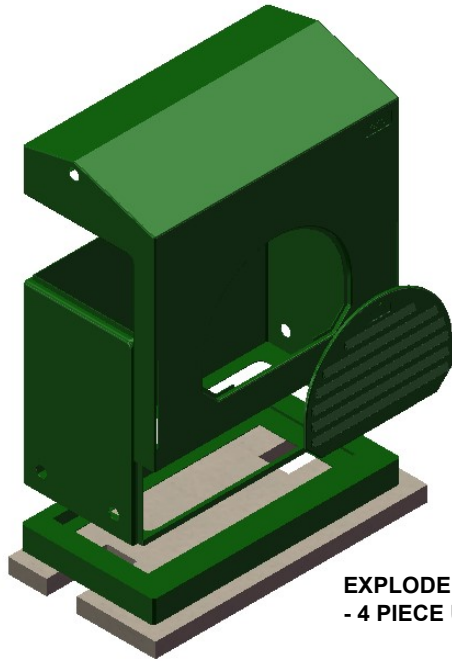

**EXPLODED VIEW - 4 PIECE UNIT**

**SECTION C-C**

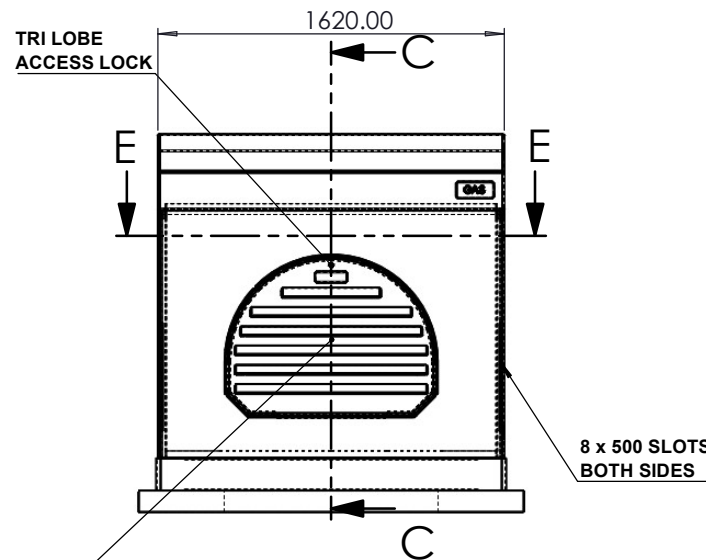
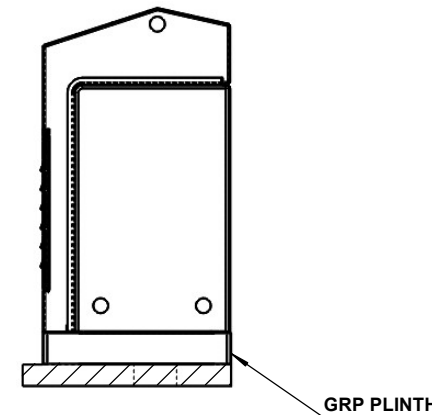

**VENTED SLATTED FRONT ACCESS PANEL (nom. 965 x 735mm)**  
**(REMOVAL ACTION - UNLOCK LEAN TOP FORWARD AND LIFT)**  
**- LOCATION HOOK ON BOTTOM EDGE.**

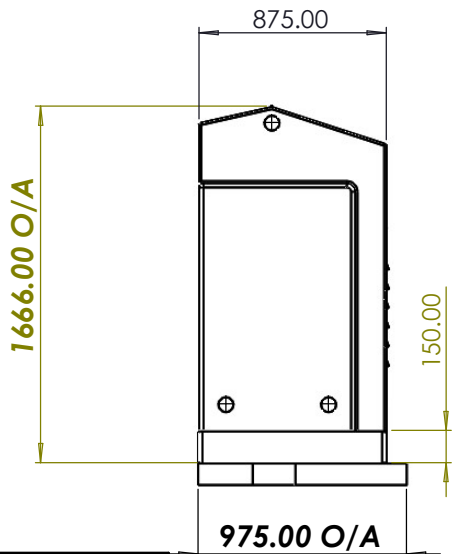

Drawing Type:-

**OVERVIEW**

Sheet :-

**1 OF 1**